



SKID LOADER
SKID LOADER
SKID LOADER
SKID LOADER



TERNE
BACKHOE LOADER
TRACTOPELLES
ANBAUBAGGER



CARRELLO ELEVATORE
FORK LIFT
CHARIOT ELEVATEUR
HOCHSTAPLER



PALE GOMMATE
WHEEL LOADERS
PELLES PNEUS
RADLADER

🇮🇹 LAMA DA NEVE STANDARD

Dotata di valvole anti urto, angolazione idraulica $\pm 30^\circ$, sistema di aurolivellamento al manto stradale $\pm 10^\circ$ e piedini di appoggio regolabili. In caso di urto è previsto il ribaltamento dell'intero versoio con ritorno a molle.

🇬🇧 STANDARD SNOW BLADE

Equipped with anti-shock valves, hydraulic angle $\pm 30^\circ$, self levelling system to the road $\pm 10^\circ$ and adjustable feet. In case of collision the entire board turns over with return springs.

🇫🇷 LAME DE DÉNEIGEMENT STANDARD

Équipé de soupape anti-choc, inclinaison angulaire $\pm 30^\circ$, système auto-nivelant à la surface de la route $\pm 10^\circ$ petits pieds d'appui. Dans le cas d'une collision est prévu renversement versoir avec l'ensemble de ressorts de rappel.

🇩🇪 STANDARD-SCHNEESCHILD

Ausgestattet mit Anti-Shock-Ventile, hydraulische Winkel $\pm 30^\circ$, Slestbnivellierungssystem auf die Straße $\pm 10^\circ$ und verstellbare FüÙe. Im Kollisionfalle der ganze Schild Kippt um mit Rückstellfedern.

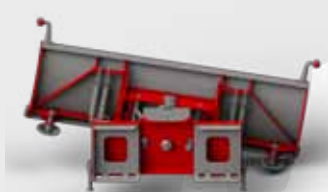

-10



-30



+10

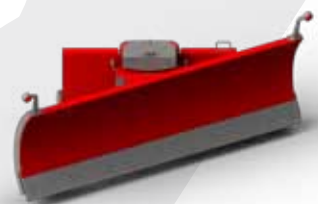

+30

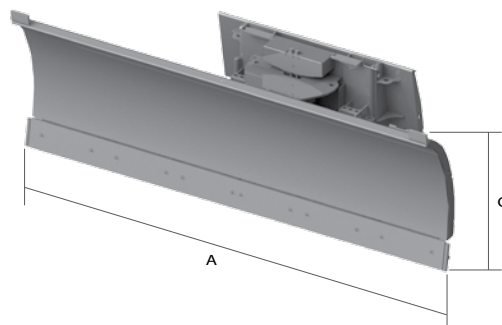



CARATTERISTICHE TECNICHE - TECHNICAL DATA - CARACTERISTIQUES TECHNIQUES - TECHNISCHE DATEN

MODELLO - MODEL - MODÈLE - MODELL		LN 1300	LN 1600	LN 1850	LN 2100	LN 2500
A	mm	1305	1605	1855	2105	2505
B (larghezza lama a 30°) - B (Blade width at 30°) B (largeur de la lame 30°) - B (Räumbreite bei Anstellwinkel von 30°)	mm	1125	1385	1605	1820	2165
C	mm	740	740	740	740	740
Peso - Weight - Poids - Gewicht	Kg	285	300	315	330	355
Pressione max - Max pressure - Pression max - Öldruck max.	bar	180	180	180	180	180

* Le associazioni verranno indicate in base alle caratteristiche della macchina. * The matching will be advise according to the technical details of the machine.
* Les associations seront indiquées sur la base des caractéristiques de la machine. * Die Auswahl ist abhängig von der Größe/Leistung des Trägerfahrzeuges.



LUCI DI INGOMBRO

Delimitano visivamente gli ingombri della lama.

BLADE POSITION LIGHTS

They visibly delimit the clearance of the blade.

LUMIÈRES

Pour délimiter visiblement les encombrements de la lame.

POSITIONSLICHTER

Die Positionslichter zeigen bei schlechten Sichtverhältnissen die Abmessungen des Schneeschildes.



FLOTTANTE COMPATTO

Permette di copiare il manto stradale senza dover correggere manualmente la posizione della lama.

COMPACT FLOATER

It enables to copy the street surface without having to manually correct the position of the blade.

FLOTTANT COMPACT

Il permet de copier le revêtement routier sans devoir corriger manuellement la position de la lame.

KOMPTAKTE SCHWIMMSTELLUNG

Sie passt das Schild selbständig der Straßenoberfläche an.

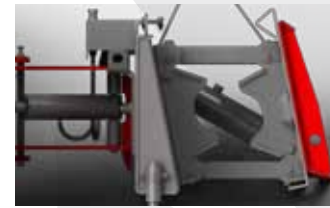

FLOTTANTE IDRAULICO

Indicato quando la macchina operatrice è sprovvista di un sistema di sollevamento.

HYDRAULIC FLOATER

Suitable when the operating machine is not equipped with a lifting system.

FLOTTANT HYDRAULIQUE

Indiqué quand la machine n'est pas équipée d'un système de levage.

HYDRAULISCHE SCHWIMMSTELLUNG

Die hydraulische Schwimmstellung ist notwendig, wenn das Trägerfahrzeug keine Hebevorrichtung hat.



OPTIONAL LAMA IN POLIURETANO

Adatta a operare su superfici a rischio danneggiamento.

OPTIONAL POLYURETHANE BLADE

Suitable for operations on surfaces at risk of damage.

LAME EN POLYURÉTHANE OPTIONNEL

Appropriée pour opérations sur surfaces à risque de dommage.

ZUBEHÖR - POLYURETHAN-LEISTE

Sie verhindert Beschädigungen an Bordsteinkanten u.ä. und sichert eine belagschonende Schneeräumung.

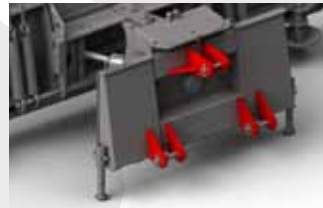

ATTACCO 3 PUNTI

3 POINT ATTACHMENT

ATTACHE 3 POINTS

ZUBEHÖR - 3-WEGE-AUFNAHME



KIT PER APPLICAZIONE SU PALE ARTICOLATE, TERNE E TELESCOPICI

APPLICATION KIT ON ARTICULATED LOADERS, BACKHOE LOADERS AND TELESCOPIC LOADERS

KIT APPLICATION SUR CHARGEURS ARTICULÉS, TRACTOPELLES ET TÉLESCOPIQUES

AUFNAHME FÜR SKID-LOADER, ANBAUBAGGER, TELESKOPLADER U.A.

* Le associazioni sono indicative, Cangini si riserva di modificare in qualsiasi momento tali associazioni.

* Not all data contained may be matching. Cangini reserves the right to modify them anytime.

* Toutes les associations sont approximatives. Cangini se réserve le droit de les modifier à tout moment.

* Alle Angaben sind ohne Gewähr. Die Firma Cangini behält sich das Recht vor, jederzeit technische Details zu ändern.